

MECHANICAL [TOP VIEW]

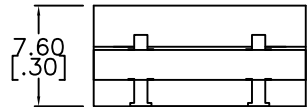

SUGGESTED PAD LAYOUT

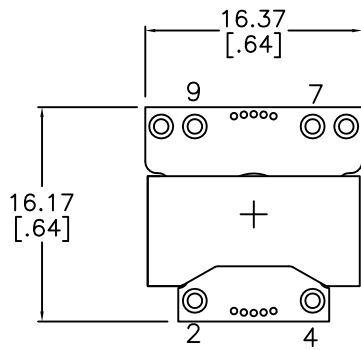
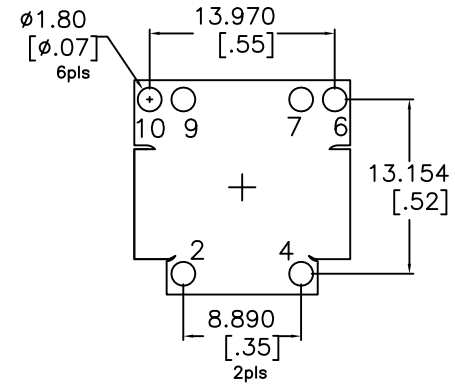

Schematic

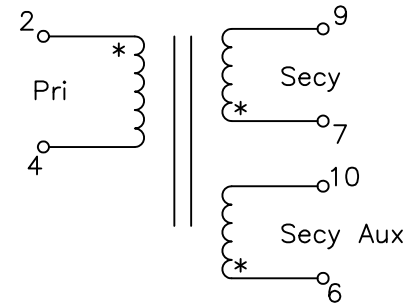

Electrical Information:

1. TURNS RATIO [7-9] : [2-4] = 4:1 ±2% || [6-10] : [2-4] = 0.667 ±2%
2. INDUCTANCE [2-4] = 22 uH Nom ±25% @100kHz/1.0V
3. LEAKAGE INDUCTANCE [2-4] : SHORT 7-9 = 120 nH Nom. @100kHz
4. DCR [2-4] = 4.6 mohms Nom, [7-9] = 91 mohms Nom., [6-10] = 300 mohms Max
5. DIELECTRIC ISOLATION: [2,4] : [7,9] > 1500 VDC
DIELECTRIC ISOLATION: [2,4] : CORE > 1500 VDC
DIELECTRIC ISOLATION: [7,9] : CORE > 500 Vdc
6. RoHS Level 6/6 Compliant | Pins 96/4 Sn/Ag Plating
7. Temperature Rating: -55C to +130C

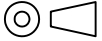
No.	DESCRIPTION	REVISIONS	DATE	APPR
THIRD ANGLE PROJECTION				
				
CHAMPS TECHNOLOGIES				
TOLERANCES/UNITS in MM UNLESS OTHERWISE INDICATED:		SIGN	DATE	Champs-Tech PN 168R1-0312-S02
.XXX ± 0.254	DRAWN	HE	3/3/15	Customer
.XX ± 0.50	CHKD			Part #:
.X ± 0.78	APPR			SIZE SCALE 2:1
ANGLE ±				ISSUE A REV 00