

1 2 3 4 5 6 7 8

SUGGESTED THRU-HOLE LAYOUT

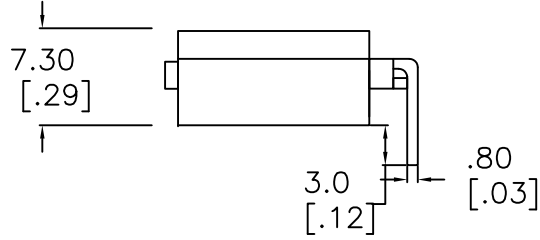

Schematic

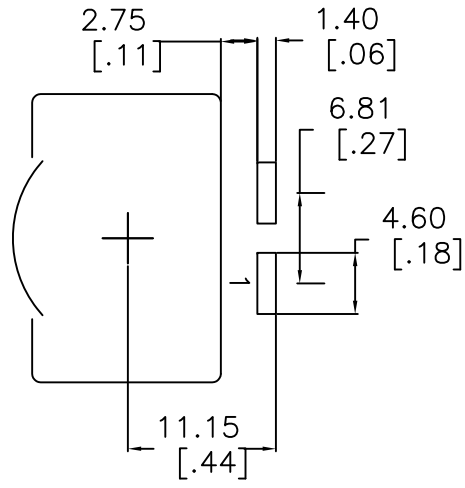
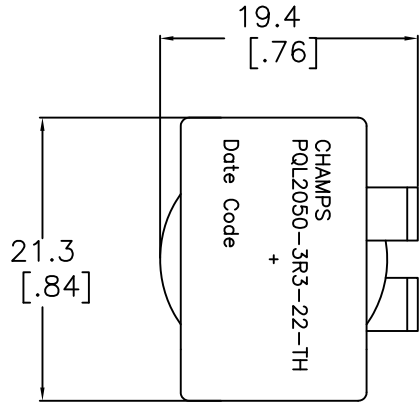
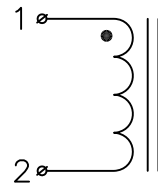

NOTES:

1. INDUCTANCE [1-2] = 3.3 uH ±10% @100kHz 1.0V @ 0Adc
2. INDUCTANCE [1-2] = Within Range ±10% Measured Value at 0Adc @Irated 22Adc
3. DCR [1-2] = 2.2 mohms Nom.
4. DIELECTRIC ISOLATION > 500 VDC [1-2] : CORE
5. SATURATION CURRENT @25C = 26Adc | @100C = 24Adc
6. HEATING CURRENT FOR 45C RISE AT 25C AMBIENT = 32 Adc
7. Operating Ambient Temperature: -55C to +130C
8. RoHS Level 6/6, REACH & CMRT Compliant || 96/4 Sn/Ag Pin Composition

No.		DESCRIPTION		REVISIONS	DATE	APPR
THIRD ANGLE PROJECTION						
CHAMPS TECHNOLOGIES						
TOLERANCES/UNITS in MM UNLESS OTHERWISE INDICATED		SIGN	DATE	Champs-Tech PN PQL2050-3R3-22-TH		
.XXX ± 0.254		DRAWN	HE	01.15.18	Customer	ISSUE
.XX ± 0.38		CHKD			Part #:	REV
.X ± 0.78		APPR			SIZE	SCALE 2:1
ANGLE ±						00